

DIAMOND PIER® DP-100E

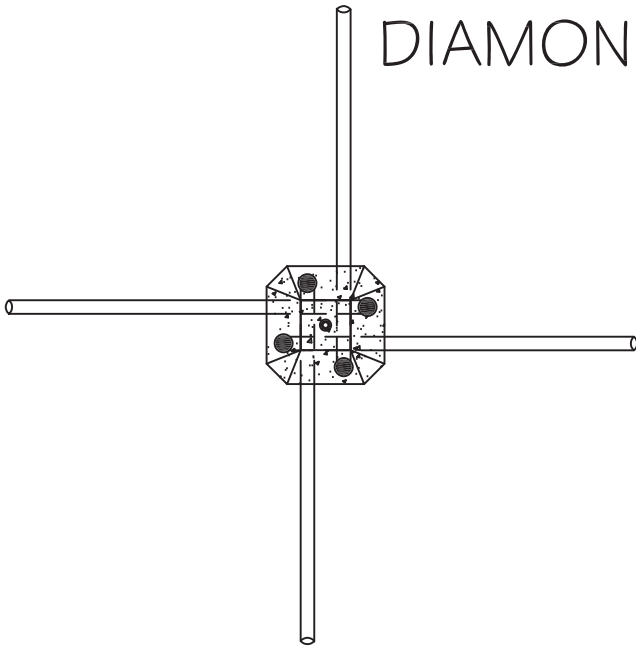

PLAN VIEW W/ PINS

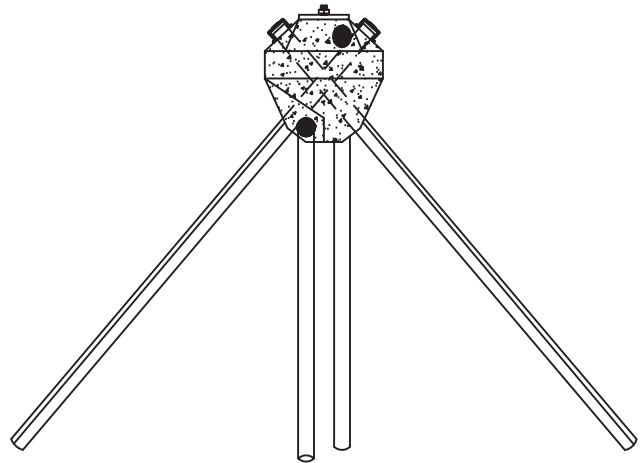

ELEVATION W/ PINS

WEIGHT 96 LBS. (CONCRETE ALONE)
 13 INCHES SQUARE AT MIDPOINT
 14 INCHES HIGH
 BRACKET SEAT - 5.5" SQUARE

1.5" NOM. DIAMETER GALVANIZED PIPE
 NOTE: LENGTH VARIES WITH SOIL CONDITIONS
 SEE MANUFACTURER'S CAPACITY GUIDELINES

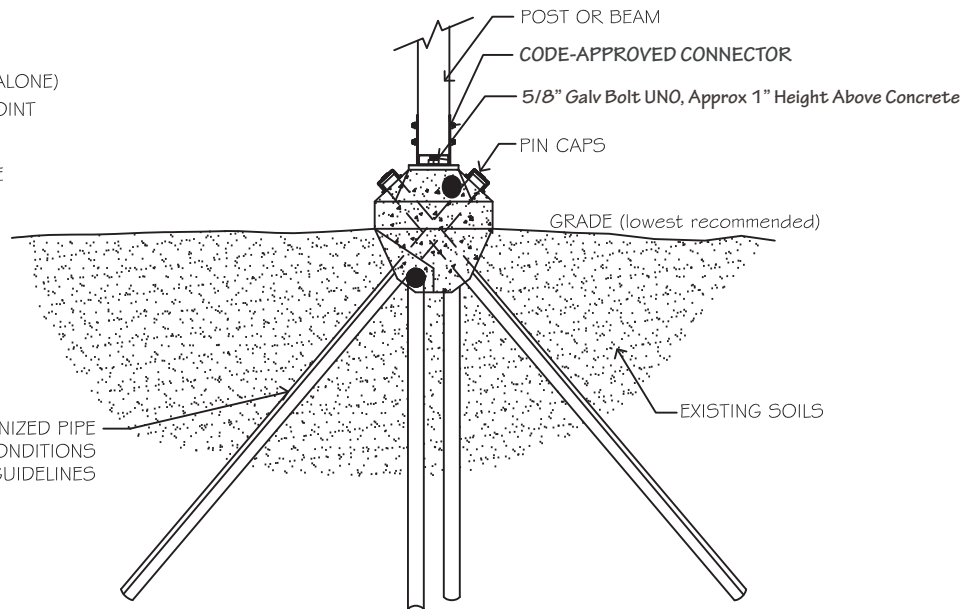

DIAMOND PIER® DP-100E

US PAT. #5039256, #6910832, & #7326003

COPYRIGHT: © 2017
 ALL DETAILS IN WHOLE, OR IN PART,
 OR ANY PORTION THEREOF ARE COPYRIGHTED
 BY PIN FOUNDATIONS, INC. AND MAY BE USED
 BY THE RECIPIENT OR THEIR ASSIGNS FOR
 PROJECT APPLICATIONS ONLY.

DOC0025/01.2017

PIN FOUNDATIONS, INC.

GIG HARBOR, WASHINGTON
 (253) 858-8809